



Rewarding Learning

ADVANCED SUBSIDIARY (AS)
General Certificate of Education
2019

Centre Number

--	--	--	--	--

Candidate Number

--	--	--	--

Physics

Assessment Unit AS 1

assessing

Forces, Energy and Electricity

MV18

[SPH11]

TUESDAY 14 MAY, MORNING

Time

1 hour 45 minutes, plus your additional time allowance.

Instructions to Candidates

Write your Centre Number and Candidate Number in the spaces provided at the top of this page.

You must answer the questions in the spaces provided.

Do not write on blank pages.

Complete in black ink only.

Answer **all ten** questions.

Information for Candidates

The total mark for this paper is 100.

Figures in brackets printed at the end of each question indicate the marks awarded to each question.

Your attention is drawn to the Data and Formulae Sheet which is inside this question paper.

You may use an electronic calculator.

1 (a) The kilogram, the ampere and the second are three of the SI base units.

(i) What is a base unit? [1 mark]

(ii) State three other SI base units. [3 marks]

(iii) The joule is the SI unit of energy. Express the joule in base units. [3 marks]

Base units of the joule = _____

(b) The Three Gorges Dam plant in China consists of a series of 32 hydroelectric power generators. It is estimated that the total energy output of this facility is 84700 GW h (gigawatt hours) per year.

(i) Show that 1 GW h is equal to 3.6×10^{12} J.
[2 marks]

(ii) Calculate the average power output of **each** generator. [3 marks]

Average power output = _____ W

2 (a) State the principle of conservation of energy. [1 mark]

(b) A hockey ball, initially at rest, is struck by a hockey stick and leaves the stick with a velocity of 19.6 m s^{-1} . The ball has a mass of 156 g.

(i) Calculate the kinetic energy of the ball as it leaves the stick. [3 marks]

Kinetic energy = _____ J

(ii) The constant force with which the ball was struck was 80.0 N. Assuming energy losses are negligible, calculate the distance over which the ball remained in contact with the stick. [2 marks]

Distance = _____ m

(iii) Calculate the power generated by the hockey player when hitting the ball. [3 marks]

Power = _____ W

3 (a) (i) State Newton's second law. [3 marks]

(ii) When a lift is accelerating upwards, why do passengers feel heavier than normal even though their mass has not changed? [2 marks]

(b) A lift, of mass 1075 kg when empty, and a 1100 kg counterweight are connected by a cable that passes over a large frictionless pulley as shown in Fig. 3.1.

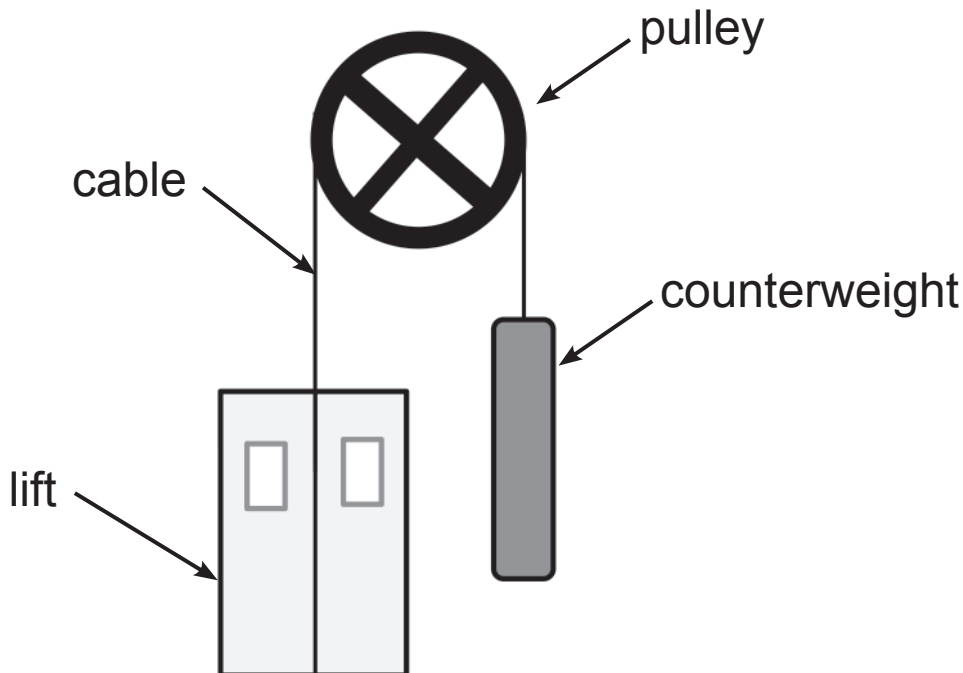

Fig. 3.1

Two passengers of masses 72.0 kg and 53.0 kg enter the lift.

- (i) Calculate the magnitude and direction of the resultant force, acting on the lift and passengers, if the lift were allowed to move freely without a brake.
[4 marks]

Resultant force = _____ N

Direction = _____

- (ii) Calculate the acceleration of the lift and passengers.
[3 marks]

Acceleration = _____ m s^{-2}

- 4 A scientist studying the motion of projectiles fires an object at an angle to the horizontal on a level surface. **Fig. 4.1** shows the initial trajectory of the projectile, launched at an angle of 40.0° to the surface and initial velocity 12.3 m s^{-1} .

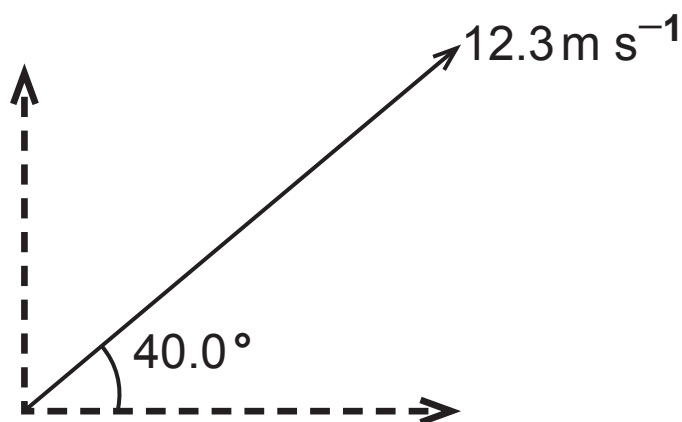

Fig. 4.1

- (a) What is projectile motion? [2 marks]

- (b) (i) Calculate the horizontal and vertical components of the initial velocity. [2 marks]

Vertical component = _____ m s^{-1}

Horizontal component = _____ m s^{-1}

- (ii) Calculate the maximum height of the projectile.
[3 marks]

Maximum height = _____ m

- (iii) Calculate the time taken to reach the maximum height. [3 marks]

Time = _____ s

- (iv) Calculate how far from the starting position the projectile landed. [3 marks]

Distance = _____ m

5 A parachute landing fall is a safety technique that allows a parachutist to practice landing without injury by stepping off an elevated static platform onto firm ground.

(a) (i) An experienced parachutist, of mass 87 kg, is to practice jumping from a 3.20 m high platform. Calculate the impulse experienced by the parachutist when landing at a velocity of 7.92 m s^{-1} . [3 marks]

Impulse = _____ N s

(ii) If the parachutist remains stiff-legged on impact, the time of impact is 4.80 ms. Calculate the magnitude of the average resultant force acting on his legs. [3 marks]

Average resultant force = _____ N

(b) The parachutist would most likely be injured during this jump. Discuss how he could improve his landing technique and explain why it works. [3 marks]

- 6** In a hotel, a lift travels non-stop from the ground floor to the 12th floor. The lift accelerates uniformly from rest for 5.0 s. It then travels at a constant velocity for 8.2 s and then decelerates uniformly for 5.0 s before stopping. Each floor of the hotel is 4.09 m high.

- (a) (i)** Sketch a velocity/time graph on the axes in **Fig. 6.1** for the lift during this journey. [1 mark]



Fig. 6.1

- (ii)** Calculate a value for the maximum velocity reached by the lift during this journey. [4 marks]

Maximum velocity = _____ m s⁻¹

(b) On **Fig. 6.2** and **Fig. 6.3**, sketch graphs of the displacement and the acceleration of the lift from the ground floor to the 12th floor. [6 marks]

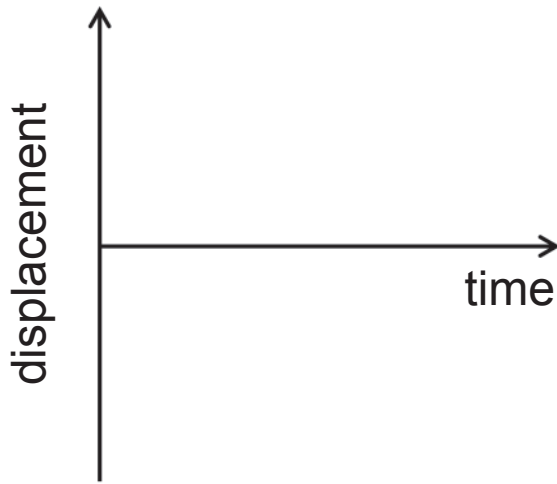

Fig. 6.2

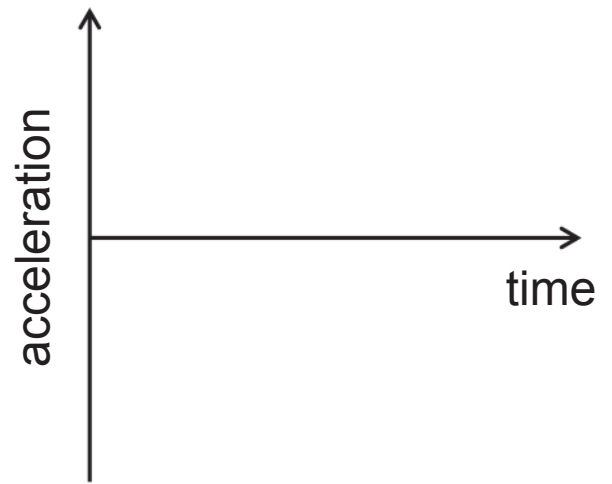

Fig. 6.3

- 7 A lighting circuit containing 6 identical bulbs is shown in Fig. 7.1.

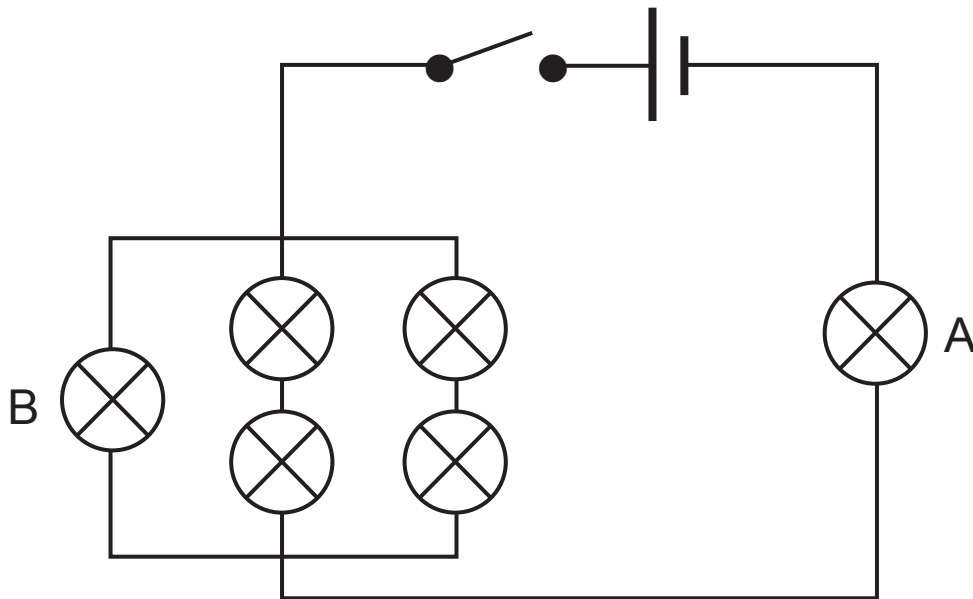

Fig. 7.1

- (a) When the switch is closed, 18×10^{19} electrons flow through bulb A every minute.

Calculate the current through bulb A. [3 marks]

Current = _____ A

- (b) The resistance of each bulb is 6.0Ω . Calculate the potential difference across the cell. [5 marks]

Potential difference = _____ V

- (c) Calculate the current that flows through bulb B when the switch is closed. [2 marks]

Current = _____ A

8 (i) In the space below, draw and label the apparatus and circuit required for a student to investigate how the resistance of a negative temperature coefficient (ntc) thermistor varies with temperature. [2 marks]

(ii) Describe how the apparatus drawn in **(i)** is used to obtain accurate results. [4 marks]

(iii) On **Fig. 8.1**, sketch the graph to show how the resistance of a negative temperature coefficient (ntc) thermistor varies with temperature. [1 mark]

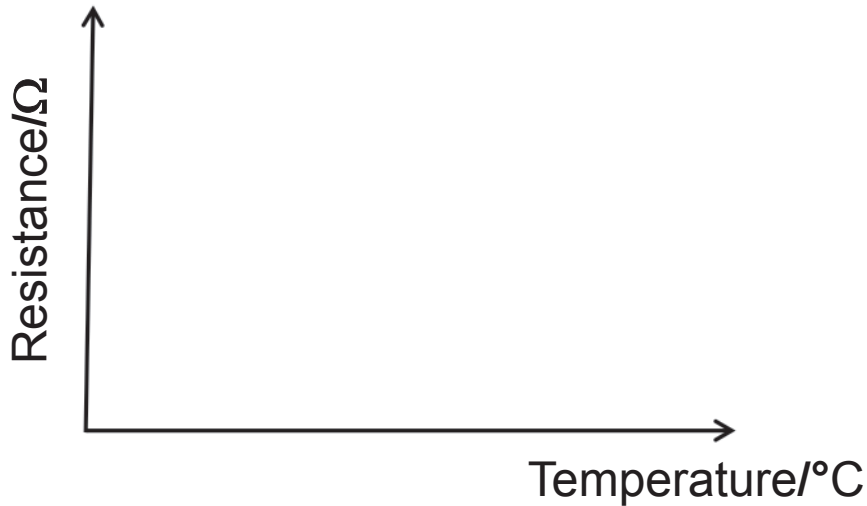

Fig. 8.1

(iv) Explain in detail why the resistance of the ntc thermistor varies with temperature in the way described by your graph. [3 marks]

- 9 (a) Define, including the types of energy involved, the **electromotive force (e.m.f.)** of a battery. [2 marks]

- (b) A battery with e.m.f. of 6.0 V and internal resistance, r , is connected to a circuit containing a $25\ \Omega$ resistor as shown in **Fig. 9.1**.

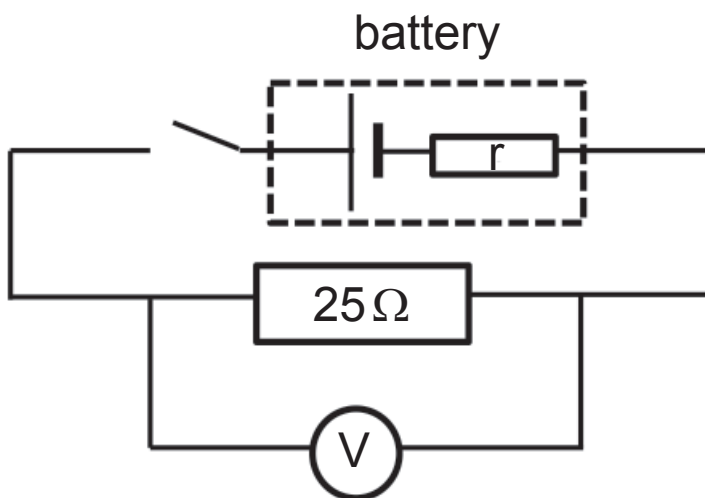

Fig. 9.1

The voltmeter used to measure the potential difference across the $25\ \Omega$ resistor has a resistance of $230\ \Omega$. The reading on the voltmeter is 5.88 V. Calculate the internal resistance of the battery. [5 marks]

Internal resistance = _____ Ω

Blank Page
(Questions continue overleaf)

10 (a) A potential divider circuit is set up as shown in **Fig. 10.1**.

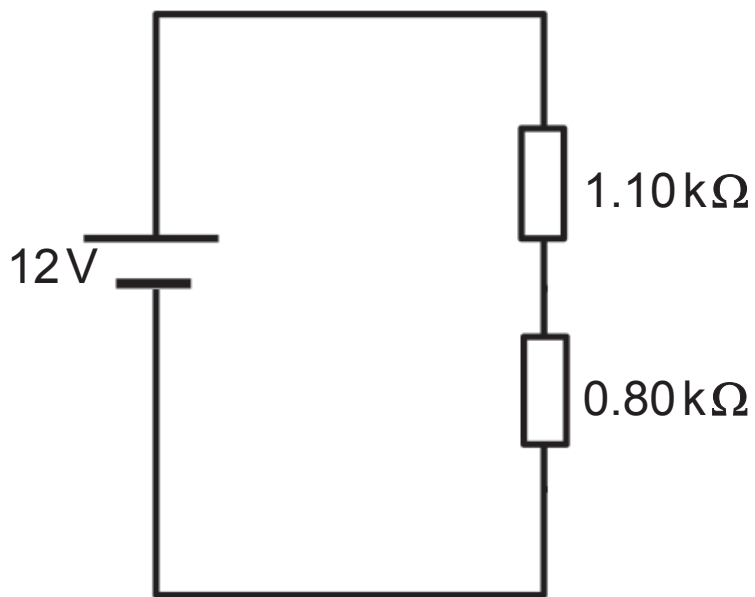

Fig. 10.1

Calculate the potential difference across the $0.80\text{ k}\Omega$ resistor. [3 marks]

Potential difference = _____ V

(b) (i) In the space below, draw a circuit diagram to show how a light dependent resistor, LDR, can be used in a potential divider circuit to automatically switch on a light bulb when it gets dark. [2 marks]

(ii) Explain briefly how this circuit allows the light bulb to be turned on automatically. [2 marks]

This is the end of the question paper

For Examiner's use only	
Question Number	Marks
1	
2	
3	
4	
5	
6	
7	
8	
9	
10	
Total Marks	

Examiner Number

Permission to reproduce all copyright material has been applied for.
 In some cases, efforts to contact copyright holders may have been unsuccessful and CCEA will be happy to rectify any omissions of acknowledgement in future if notified.



Rewarding Learning

ADVANCED SUBSIDIARY
General Certificate of Education

Physics

Assessment Units AS 1 and AS 2

[SPH11/SPH21]

DATA AND FORMULAE SHEET

for use from 2017 onwards

Data and Formulae Sheet for AS 1 and AS 2

Values of constants

speed of light in a vacuum	$c = 3.00 \times 10^8 \text{ m s}^{-1}$
elementary charge	$e = 1.60 \times 10^{-19} \text{ C}$
the Planck constant	$h = 6.63 \times 10^{-34} \text{ J s}$
mass of electron	$m_e = 9.11 \times 10^{-31} \text{ kg}$
mass of proton	$m_p = 1.67 \times 10^{-27} \text{ kg}$
acceleration of free fall on the Earth's surface	$g = 9.81 \text{ m s}^{-2}$
electron volt	$1 \text{ eV} = 1.60 \times 10^{-19} \text{ J}$
the Hubble constant	$H_0 \approx 2.4 \times 10^{-18} \text{ s}^{-1}$

Useful formulae

The following equations may be useful in answering some of the questions in the examination:

Mechanics

conservation of energy	$\frac{1}{2} mv^2 - \frac{1}{2} mu^2 = Fs$ for a constant force
------------------------	--

Waves

two-source interference	$\lambda = \frac{ay}{d}$
diffraction grating	$d \sin\theta = n\lambda$

Light

lens equation

$$\frac{1}{u} + \frac{1}{v} = \frac{1}{f}$$

Electricity

terminal potential difference

$$V = E - Ir \text{ (e.m.f., } E; \text{ Internal Resistance, } r)$$

potential divider

$$V_{\text{out}} = \frac{R_1 V_{\text{in}}}{R_1 + R_2}$$

Particles and photons

Einstein's equation

$$\frac{1}{2} m v_{\text{max}}^2 = hf - hf_0$$

de Broglie equation

$$\lambda = \frac{h}{p}$$

Astronomy

red shift

$$z = \frac{\Delta\lambda}{\lambda}$$

recession speed

$$z = \frac{v}{c}$$

Hubble's law

$$v = H_0 d$$

